



Space Infantry Pocket

v1.08 / 2026-06-03

gamesbyfelix.com

Acknowledgements

This is a fan project created by gamesbyfelix.com for the Space Infantry: Resurgence (SI:R) board game. A copy of Space Infantry: Resurgence and familiarity with its rules are required to play. Art created with perchance.org.

Space Infantry is an original game series designed by Gottardo Zancani and published by Lock’N’Load Publishing.

<https://zak965.it>

<https://lnlpublishing.com>

Table of Contents

Introduction	3
Requirements	3
The Mission Map	4
Map Creation Procedure	6
Objective Placement Procedure	7
The Enemy	8
Enemy Creation Procedure	9
Combat Log	10
Your Squad	11
Game Turns	12
Winning and Losing	12
Optional Rules	13
Tough Objectives	13
Even Tougher Objectives	13
Objective Caches	13
Fewer Shortcuts	13
Demolition Experts	13
Dead End	13
Original Enemies	13
More Mission Maps	14
Creating Your Own Mission Maps	14
Variant: Base Defense	15
Changelog	19
Play Sheets	20

Introduction

This is a travel-friendly version of the Space Infantry: Resurgence core game. It delivers a very similar experience, using the original rules for dice rolling, squad movement, skill checks, combat, etc., with adjusted rules for map creation, squad creation and enemy setup. Visit gamesbyfelix.com for the latest version of this PDF and reach out via e-mail if you have questions or ideas for expanding this ruleset.

Space Infantry Pocket is a roll-and-write game, played on a single piece of paper, called the “play sheet”, of which you find several at the back of this PDF. Start with the “Mission Map 01” play sheet, if you’re new to the game. You write on it with a pencil, roll dice, make decisions and use an eraser to change any values as your mission progresses. You can also play on a computer or tablet with a digital pen and a dice app.

You start by creating the mission map, placing objectives and rolling the enemy’s attributes. Then you assemble your squad and start playing.

Mission Map

Turns

01	13
02	14
05	15
04	16
05	17
06	18
07	19
08	20
09	21
10	22
11	23
12	24

Squad

Leader	F	F	F	F	Spec 1
	M	M	M	M	Spec 2
CMD	4	ADV 3	ADV 3	ADV 3	
CP	0	0	0	0	

Resources I M G SG D S

Enemies

Type I	Type II	Ranges	Melee	Fire	EPT	D6	A	B	
F	F				1	11	21		
M	M				2	21	21	111	
	Special:				3	31	31	111	
					4	41	41	111	
					5	51	51	211	
					6	21	111	41	311

Notes

Space Infantry Pocket Play Sheet gamesbyfelix.com

Requirements

- A print-out of a play sheet (last pages of this PDF, start with Mission 01).
- A pencil.
- An eraser.
- The two differently-colored dice from SI:R.
- The soldier, specialist and equippable cards from SI:R.
- Optional: The Squad A counter from SI:R to mark your position on the map.

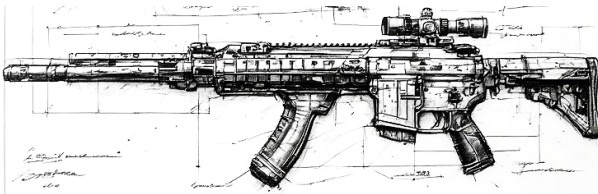

The Mission Map

You begin the game setup by creating the mission map at the top of the play sheet. It consists of 12 locations, also called “nodes”, arranged in a 3x4 grid. Your squad starts in the location labelled “Start”. To win, your squad needs to enter three “Objective” locations in any order. One objective is printed on the map and the other two are set up randomly (see page 7).

Locations are linked by little circles connected to dotted lines, emphasized in red in the image below.

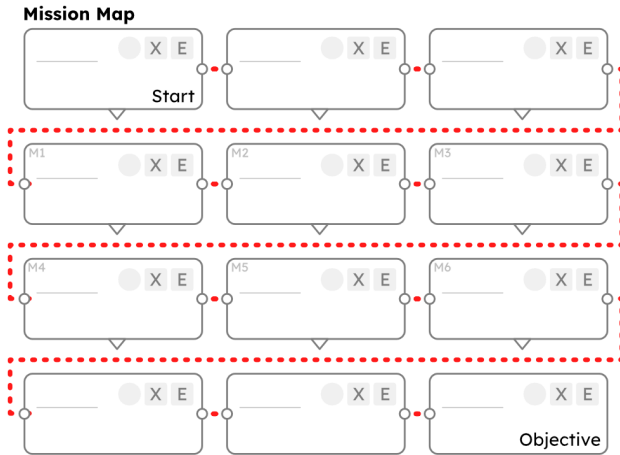

There might also be shortcuts, drawn as a straight line from a location’s small triangle to the location that the triangle tip is pointing to (emphasized in red in the image below). A shortcut line links both locations.

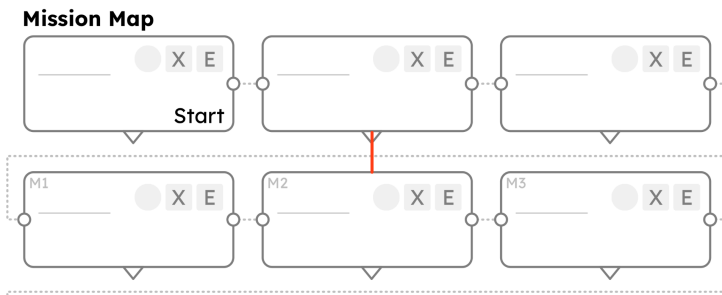

You may move your squad back and forth between linked locations, adhering to the SI:R core rules, including rolls for node resolution, events and back-tracking.

Once you enter a location by passing its skill check, you circle the X with your pencil, which substitutes the multi-purpose counter from the SI:R core game.



When you roll an event, you circle the E, to mark that an event has occurred. This substitutes the event counter from SI:R.



If there is an equipment cache at the location, you write the equipment type's letter in the grey circle. E.g. "M" for Med Kit, "I" for Intel, "G" for Grenades.

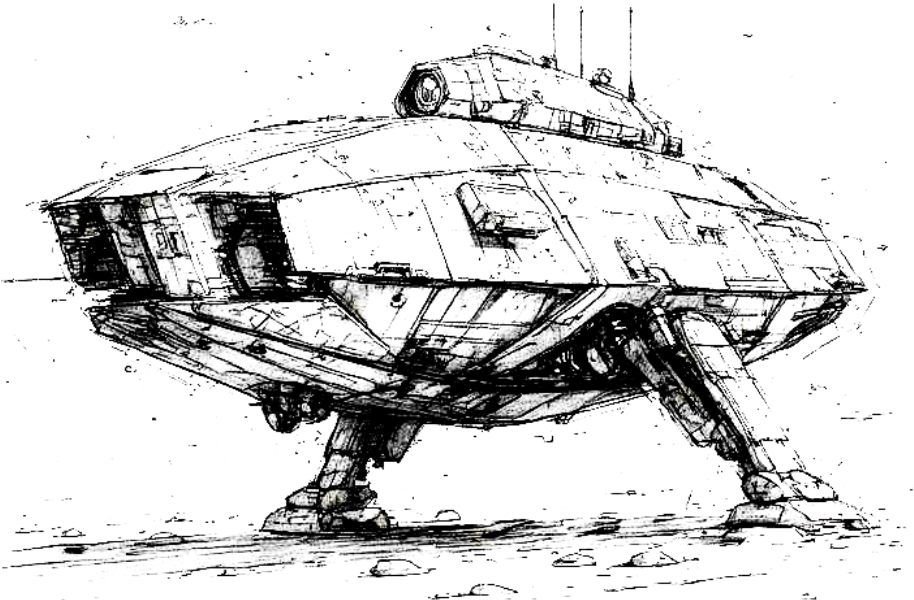

Map Creation Procedure

Roll four D6 on the table below for each location. One for the encounter event, one for the skill type required to enter, one for the skill level and one for a special attribute. Write down the results inside the location's box.

D6	Encounter	Skill	Lvl	Special
1	4+/B *	Tracking (TRA)	4	-1 Turn **
2	5+/B *	Science (SCI)	3	None
3	4+/A	Engineering (ENG)	2	None
4	5+/A	Demolitions (DEM)	2	None
5	5+/A	Advance (ADV)	2	Cache ***
6	6+/A	Advance (ADV)	1	Shortcut ****

* Maximum three X+/B encounters on the map. Re-roll any further results.

** Strike through the highest turn number on the Turns track. You have one fewer turn to finish the mission. Maximum three times. Ignore further results.

*** Maximum three caches on the map. Ignore further roll results.

Immediately roll one D6 for the cache type and write its first letter in the location's grey circle:

1-2: Med Kit 3-4: Grenades 5-6: Intel

**** Draw a line from the location's triangle to the location the triangle tip is pointing to. These two locations are now linked (see example on page 4). Ignore the result on locations without a triangle.

Example:

You roll a 4 for "5+/A",
a 2 for "Science (SCI)",
and a 5 for "2".

You roll a 3 for the special
attribute, which is "none".

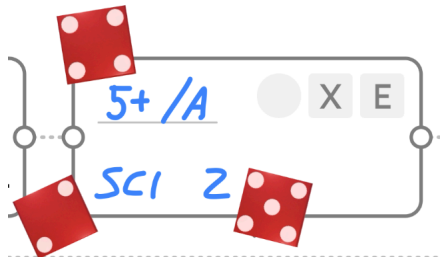

Objective Placement Procedure

After creating the map, roll two D6 to mark two of the M1 - M6 locations as mission objectives. Re-roll doubles, so that two different locations are marked. To win the mission, you need to move into each of the three objective locations and finish your turn there. You do not have to fight in these locations to win the mission, unless you roll a combat encounter during the event roll step.

Example:

You roll a 2 and a 4, so you mark locations M2 and M4 as objectives.

Mission Map

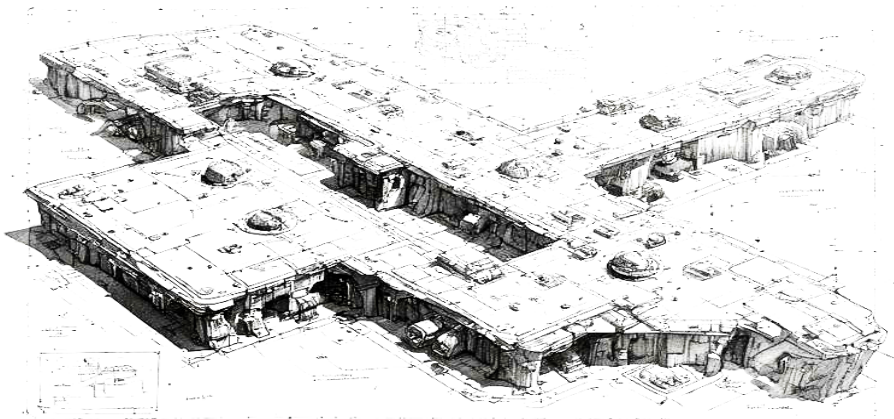

The Enemy

The enemy force is set up randomly after placing the objectives. There are Type I and Type II enemies with fire and melee skills, as well as special attributes, for example armor or AP bonuses. Type I units can always suffer two wounds (indicated by two heart icons) and Type II units can always suffer three wounds. Encountering enemies and fighting them works the same way as in SI:R. You roll on the EPT, generate command points, check the range, generate wounds, etc.

The play sheet has an “Enemies” section where you write down the enemy attributes and the range table. The range table is simplified, compared to the ones found on the original SI:R enemy sheets.

The section also contains the Enemy Placement Table (EPT), on which you roll to determine how many enemy units you encounter for combat.

Example: Rolling a 5 on the B column of the EPT has you fight three Type I enemies (3I) and two Type II enemies (2II).

Enemies

Type I F <u>4</u> M <u>3</u>	Type II F <u>4</u> M <u>2</u> Special: <i>1 Armor</i>	Ranges Melee Fire <u>1 - 4</u> <u>5 - 6</u> ↓ ↓	EPT <table border="1"> <thead> <tr> <th>D6</th> <th>A</th> <th>B</th> </tr> </thead> <tbody> <tr><td>1</td><td>1I</td><td>2I</td></tr> <tr><td>2</td><td>2I</td><td>2I 1II</td></tr> <tr><td>3</td><td>3I</td><td>3I 1II</td></tr> <tr><td>4</td><td>4I</td><td>4I 1II</td></tr> <tr><td>5</td><td>5I</td><td>3I 2II</td></tr> <tr><td>6</td><td>2I 1II</td><td>4I 3II</td></tr> </tbody> </table>	D6	A	B	1	1I	2I	2	2I	2I 1II	3	3I	3I 1II	4	4I	4I 1II	5	5I	3I 2II	6	2I 1II	4I 3II
D6	A	B																						
1	1I	2I																						
2	2I	2I 1II																						
3	3I	3I 1II																						
4	4I	4I 1II																						
5	5I	3I 2II																						
6	2I 1II	4I 3II																						
			Notes																					

Enemy Creation Procedure

Roll three D6 on the table below for the mission's enemy attributes. One for Type I units, one for Type II units (this includes the range table) and one for the Type II units' special attribute. Write down the results on the play sheet.

D6	Type I	Type II & Range	Type II Special
1	F: 3 M: 3	F: 2 M: 4 1-2 Melee*	Fire & Melee +1 AP
2	F: 3 M: 4	F: 4 M: 2 1-4 Melee*	A.P. Fire Damage **
3	F: 3 M: 4	F: 2 M: 5 1-2 Melee*	Fear ***
4	F: 4 M: 3	F: 5 M: 2 1-4 Melee*	2 Armor
5	F: 4 M: 3	F: 3/4 M: 3 1-3 Melee*	1 Armor
6	F: 4 M: 4	F: 3 M: 3/4 1-3 Melee*	1 Armor

* This is the previously-mentioned simplified range system, showing the D6 results for melee combat. A D6 result above means fire combat.

** Armor Piercing damage for fire skill attacks.

*** See 13.1 in the SI:R rulebook.

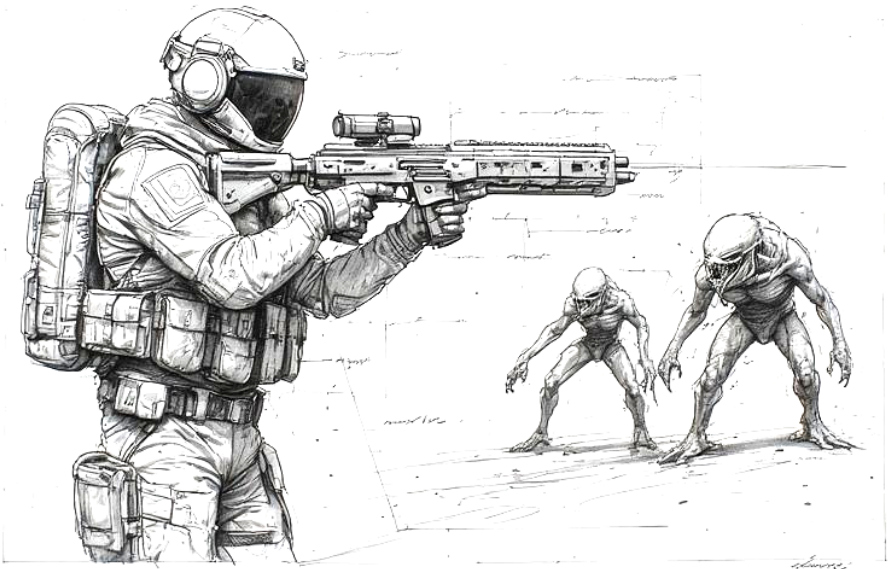

Combat Log

Below the Type I, Type II and Ranges box is the combat log. Whenever you start a combat encounter, after rolling on the EPT, mark how many Type I and Type II enemies you encounter. During combat you can assign wounds to each enemy unit by crossing out the respective heart icons. If a Type II enemy has armor, you can indicate this using the small “A” icons (see the example image below, or on page 8).

You can also keep track of the combat range (fire/melee) for each combat turn, by crossing off a circle in the columns below the Ranges box.

After a combat encounter is resolved and all enemy units are killed, erase the combat log.

Example:

You encounter three Type I enemies and two Type II enemies, the latter of which have one point of armor (A). It is combat turn four and you're in melee range (crossed circles below the Ranges box). The first Type I enemy is dead (two hearts crossed off) and the third has one wound. The first Type II enemy has two wounds.

Enemies		
Type I	Type II	Ranges
F <u>4</u>	F <u>4</u>	Melee Fire
M <u>3</u>	M <u>2</u>	<u>1 - 4</u> <u>5 - 6</u>
	Special: <u>1 Armor</u>	↓ ↓
♥ ♥	♥ ♥ ♥ (A) ♥	○ 1 ○
♥ ♥	♥ ♥ ♥ (A) ♥	○ 2 ○
♥ ♥	♥ ♥ ♥ (A) ♥ ♥	○ 3 ○
♥ ♥	♥ ♥ ♥ (A) ♥ ♥	○ 4 ○
♥ ♥		○ 5 ○
♥ ♥		○ 6 ○
♥ ♥		○ 7 ○
♥ ♥		○ 8 ○

Your Squad

Squad creation is slightly simplified compared to SI:R. You may spend up to the usual 110 points to assemble your squad, using any soldiers, specialists and equippables from SI:R. The squad leader is always part of your squad. They may take up to four soldiers and two specialists with them. Each squad member only has one skill. The leader has “Command 4”, soldiers always have “Advance 3” (even Heavy Weapons) and for your specialists you may choose one skill from their SI:R card. Specialists and the leader cannot engage in fire and melee combat, but they can each be assigned one wound at any time.







Write down your squad members’ names, skills and other attributes (e.g. armor) in the corresponding boxes on the play sheet.

You may bring up to eight resources. Write down the amount in the “Resources” section of the play sheet. Equipment caches in locations on the mission map work just like in SI:R (roll for the amount, minus one). Your squad can never carry more than a total of eight resources.

Note your squad’s position on the mission map with your pencil or a token. You start at the location labelled “Start”.

Example: You’re in the middle of a game. Your leader just generated one command point with their command skill (one cross after “CP”). Fire Team B has one wound (crossed-out heart). The C-C Team has one wound and its typical one point of armor (A). Specialist 1 is dead, having suffered one wound. Your squad carries two Intel (I), four Med Kits (M), one Grenade (G), no Smoke Grenades (SG), one Demo Charge (D) and no Stym Packs (S).

Squad

Leader  CMD 4 CP <input checked="" type="checkbox"/> <input type="checkbox"/> 	Fire Team A F 3 M 4 ADV 3  	Fire Team B F 3 M 4 ADV 3 <input checked="" type="checkbox"/> 	A-Team A F 4 M 3 ADV 3  	C-C Team F 4 M 3 ADV 3 <input checked="" type="checkbox"/>  A	Spec 1 Sci 3 <input checked="" type="checkbox"/> Spec 2 Eng 3 
Resources I M G SG D S					

Game Turns

The sequence of play is the same as in SI:R.

1. Advance the turn marker. *
2. Roll for CP.
3. Move to a linked location, using a skill check and/or intel if you haven't been there before (if you have, roll a back-tracking check).
4. Roll for a combat event and if combat occurs, roll on the EPT. Then, during combat do the following:
 - 4.1 Roll for CP.
 - 4.2 Roll for this combat turn's range.
 - 4.3 Generate wounds for an enemy's attack and assign them to your squad members.
 - 4.4 Generate wounds for one of your soldiers and assign them to enemy units.
 - 4.5 Repeat 4.3 and 4.4 until all units have generated wounds.
 - 4.6 Remove casualties and go back to 4.1 until combat is resolved.

* Simply cross off the corresponding number on the play sheet's Turns track with your pencil. In Space Infantry Pocket there are generally fewer turns to play than the 30 in SI:R.

Turns	
13	13
14	14
15	15
04	16

Winning and Losing

Once you have entered the third objective location, you win the game at the end of your turn, meaning you still have to roll for the location's event. You may enter the objective locations in any order.

You lose if you haven't entered all three objective locations by the end of the last turn on the Turns track, or if your squad is killed.

Optional Rules

Tough Objectives

After placing the objectives, if there are fewer than three X+/B encounters on the map, change a random objective location encounter to 5+/B. Repeat until three locations on the map have X+/B encounters.

Even Tougher Objectives

After placing the objectives, change each objective location encounter to 4+/B, even if this means that there are more than three X+/B locations on the map now.

Objective Caches

When creating the map, don't place any random equipment caches. Instead, after placing the objectives, add a random cache to each of the two M1 - M6 mission objective locations.

Fewer Shortcuts

There can only be two shortcuts on the map. If you roll more than two during map creation, ignore the result.

Demolition Experts

Once per mission, instead of moving your squad, any squad member may use a demo charge resource to create a shortcut at the current location. Draw a line from the location's triangle to the location the triangle tip is pointing to. These two locations are now linked.

Dead End

When playing with the "Demolition Experts" optional rule, roll a D6 after map creation to determine one M1 - M6 location. Strike through a random regular link (dotted line) from this location. Your squad cannot move along this link anymore and may need to create a shortcut with a demo charge to progress.

Original Enemies

Instead of rolling random enemies, fight against the original SI:R enemies.

More Mission Maps

At the back of this PDF you find several play sheets. Play with the “Mission Map 01” sheet first, to get a feeling for the game and then explore the others.

Creating Your Own Mission Maps

At the back you also find a blank “DIY Play Sheet”. You may use it to create your own missions, by connecting the locations in an interesting way. Add circles and dotted lines for location links and add triangles for possible shortcuts.

Designate six locations with the M1 - M6 keywords for mission objective placement. Add one fixed mission objective to another location and add the “Start” keyword to yet another one.

Write a new EPT that feels suitably difficult for your mission, or copy the table from Mission 01 and test how it plays. Finally, choose the amount of turns the player has to finish the mission. Count the amount of locations for the shortest/best path that the squad must take to win (without shortcuts) and double the result, with a maximum of 24. E.g. in Mission 01, without shortcuts, the squad would have to move through 12 locations (including the starting location), so the player gets 24 turns.

If you create a fun mission map, send me a picture of it and I will include it in a future update of this PDF. Also send me your name, if you want to be credited.

Variants: Base Defense

In this game variant your squad must defend their base against incoming enemies. The gameplay rules are mostly the same as before, with the differences and additions being explained below. You play on the special “Base Defense” play sheet found at the back of this PDF.

Winning and Losing

You win at the end of turn 24.

You lose if your squad is killed or if four locations are destroyed.

Mission Map & Locations

The Mission Map is ready to play in this variant, so you don’t roll on a table to populate it with skill checks and encounters during setup. Each location starts with “Advance 0” (ADV), so moving into it doesn’t require a skill check. Every point of damage to a location adds one to its “Advance” level. A location is permanently destroyed and becomes impassable if it receives its fifth point of damage.

Example: Location M1 has received two points of damage (crossed-out circles) and thus requires an “Advance 2” skill check to enter. The HQ location is not damaged and doesn’t require a skill check. Location M2 has five points of damage (the fifth crossed out the whole location) meaning it is destroyed and cannot be entered anymore.

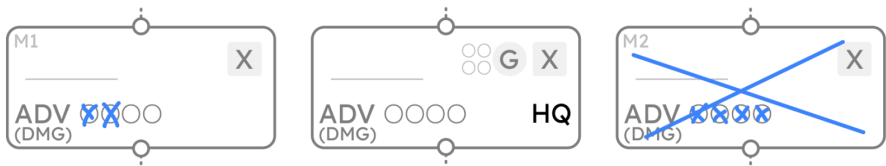

The Enemy

The enemy forces are rolled as per the [Enemy Creation Procedure](#) (page 9).

Your Squad

Squad creation works as before. You may spend up to 110 points, however you don’t take any specialists. You can take up to five soldiers in addition to the squad leader.

Your squad starts the game in the HQ location.

Turn Sequence

1. Advance turn marker
2. Enemy arrival
3. Generate and spend CP
4. Squad movement
5. Combat resolution
6. Enemy actions
7. Resupply

Turns

01-A	13-A
02-A	14-A
03-A	15-A

1. Advance turn marker

Circle the next turn number on the play sheet's Turns track.

2. Enemy arrival

Roll one D6 for the enemy arrival location (M1 - M4). On a roll of five or six, no enemy arrives. If an enemy arrives, check for the letter A or B behind the current turn number on the Turns track. Roll one D6 on the according EPT column and write the result in the location. An enemy is in the location now.

Example: It's turn 01-A. You roll a D6 for the location, resulting in a 4. You roll a D6 on the EPT's A column with a result of 2. You write "A2" in location M4.

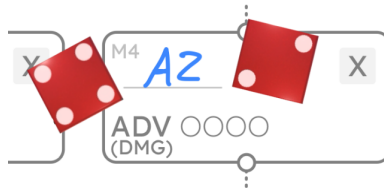

If there is already an enemy in the rolled location, increase its EPT value by one, to a maximum of six (e.g. an A3 enemy becomes an A4 enemy) and add one point of damage to the location. Cross out a circle after ADV and erase any circle around the X in the top right corner of the location.

If the rolled location has previously been destroyed, don't add an enemy to it, but re-roll until a location is rolled which is not destroyed.

If your squad is in the enemy arrival location, no combat happens yet. You may move away from the location in the squad movement phase, or stay and resolve combat in the combat resolution phase.

3. Generate and spend CP

If your leader is still alive, roll their command skill to generate CP as usual. If you successfully generated any CP, you may freely spend them on the following special actions now.

Spend one CP ...

- ... for one additional squad movement in the next phase.
- ... to repair one point of damage at one location without an enemy (erase a crossed-out circle). Destroyed locations cannot be repaired.
- ... to reduce an enemy's EPT value by one, to a minimum of one. E.g. an A3 enemy becomes an A2 enemy.
- ... to block one link between two locations for this turn. Your squad may still move along the link, but the enemy cannot, making them choose another route if they move during the enemy actions phase.

Left-over CP are lost after the squad movement phase of the turn sequence.

4. Squad movement

Squad movement works the same as before. Upon successfully entering a location you circle the X, however there are no event checks and no back-tracking rolls.

Each location starts with Advance 0 (ADV), so moving into it is free. Every point of damage to a location adds one to its Advance level. You may use CP to help you with Advance skill checks as usual.

You may perform one move action per turn, unless you have spent CP on one or two additional moves. A failed Advance skill check when trying to enter a location counts as a move. You must end the squad movement phase immediately, if your squad enters a location with an enemy.

Example: Your squad has gained an additional movement this turn from spending CP. First, it wants to move into a location that has two points of damage, which requires an Advance 2 skill check. The check succeeds and the squad moves into the location. There is no enemy there, so the squad may perform its second move. The destination is a location without any damage, so there is no skill check required.

5. Combat resolution

If your squad is in a location with enemies, you must resolve the combat now. Combat works the same as before.

6. Enemy actions

Roll one D6 on the table below for every enemy on the play sheet. Start with the enemy closest to the HQ or MedBay (M.Bay) location.

D6	Enemy Action
1-3	Move the enemy one location toward the HQ or MedBay. *
4-5	Add one point of damage to the location. **
6	Add two points of damage to the location. **

* Move the enemy along the shortest possible path toward the HQ or M.Bay (whichever is closest). If the enemy moves into your squad's location, resolve combat immediately. If the enemy is already in the HQ or M.Bay, add one point of location damage instead of moving. If the way is blocked by another enemy, or if the enemy is boxed-in by impassable locations, add one point of damage instead of moving. Ignore any Advance skill checks.

** If your squad has been in the location before, erase the circle around the X. Your squad needs to succeed the location's Advance skill check again to enter. If the location receives its fifth point of damage, it is permanently destroyed and impassable. In that case, erase the enemy on it and cross off the whole location box with a big X. You lose if four locations are destroyed.

7. Resupply

The HQ location has a resource cache for grenades and smoke grenades. The MedBay (M.Bay) location has a medkit cache. If your squad is in one of these locations, it may take the according resources up the carrying limit of eight resources total.

Each cache contains four resources. If you take one, fill out a little circle next to the G or M in the location box. The caches are depleted after the fourth resource has been taken.

Changelog

1.08: added rules for the “Base Defense” variant, added the “Base Defense” play sheet

1.07: added “Mission Map 04”, small fix on “Mission Map 03”, minor fixes and improvements

1.06: nicer-looking tables, added the “Mission Map 03” play sheet, minor clarifications and fixes

1.05: added “-1 Turn” result during map creation, opened up the rules to other map layouts, added the “Mission Map 02” play sheet and the “DIY Play Sheet”, added this changelog, minor fixes and improvements

1.01: initial release

Play Sheets

On the next pages you find the play sheets.

Mission Map #01

Turns

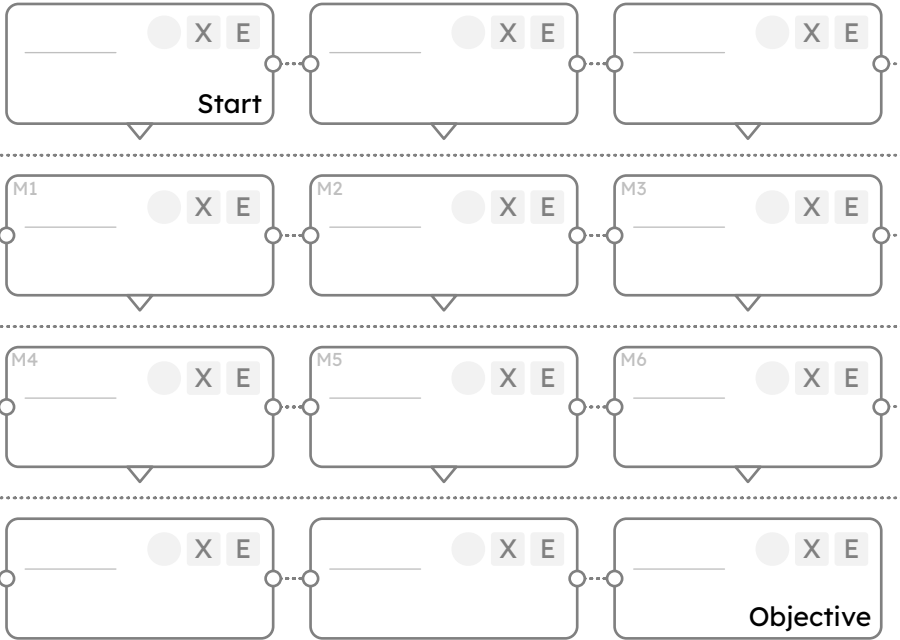

01	13
02	14
03	15
04	16
05	17
06	18
07	19
08	20
09	21
10	22
11	23
12	24

Squad

Leader	F M	F M	F M	F M	Spec 1
★	ADV 3	ADV 3	ADV 3	ADV 3	♥
CMD 4					Spec 2
CP ○ ○					
♥	♥ ♥	♥ ♥	♥ ♥	♥ ♥	♥

Resources I _____ M _____ G _____ SG _____ D _____ S _____

Enemies

Type I	Type II	Ranges	EPT
F _____	F _____	Melee _____ Fire _____	D6 A B
M _____	M _____	- -	1 1I 2I
	Special: _____	↓ ↓	2 2I 2I 1II
♥ ♥	♥ ♥ ♥ (A) (A)	○ 1 ○	3 3I 3I 1II
♥ ♥	♥ ♥ ♥ (A) (A)	○ 2 ○	4 4I 4I 1II
♥ ♥	♥ ♥ ♥ (A) (A)	○ 3 ○	5 5I 3I 2II
♥ ♥		○ 4 ○	6 2I 1II 4I 3II
♥ ♥	🔴 🔴 🔴	○ 5 ○	Notes
♥ ♥		○ 6 ○	
		○ 7 ○	
		○ 8 ○	

Mission Map #02

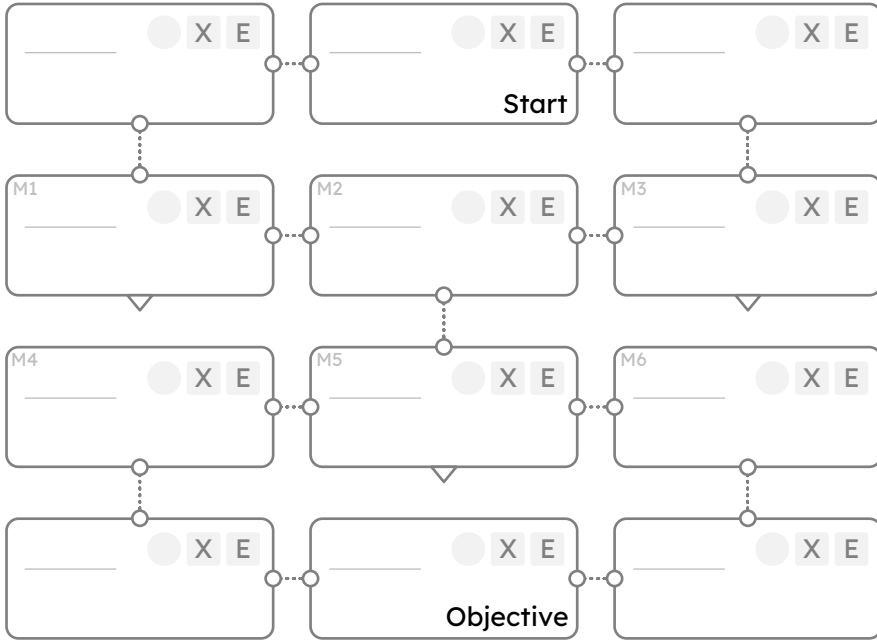

Turns

01	13
02	14
03	15
04	16
05	⊗
06	⊗
07	⊗
08	⊗
09	⊗
10	⊗
11	⊗
12	⊗

Squad

Leader CMD 4 CP ○ ○ ♥	F _____ M _____ ADV 3 ♥ ♥	F _____ M _____ ADV 3 ♥ ♥	F _____ M _____ ADV 3 ♥ ♥	F _____ M _____ ADV 3 ♥ ♥	Spec 1 _____ ♥ Spec 2 _____ ♥
---	------------------------------------	------------------------------------	------------------------------------	------------------------------------	--

Resources I _____ M _____ G _____ SG _____ D _____ S _____

Enemies

Type I F _____ M _____ ♥ ♥ ♥ ♥ ♥ ♥ ♥ ♥ ♥ ♥	Type II F _____ M _____ Special: _____ ♥ ♥ ♥ (A) (A) ♥ ♥ ♥ (A) (A) ♥ ♥ ♥ (A) (A) 	Ranges Melee _____ Fire _____ - - ○ 1 ○ ○ 2 ○ ○ 3 ○ ○ 4 ○ ○ 5 ○ ○ 6 ○ ○ 7 ○ ○ 8 ○	EPT <table border="1"> <thead> <tr><th>D6</th><th>A</th><th>B</th></tr> </thead> <tbody> <tr><td>1</td><td>2I</td><td>4I</td></tr> <tr><td>2</td><td>3I</td><td>3I 1II</td></tr> <tr><td>3</td><td>4I</td><td>4I 1II</td></tr> <tr><td>4</td><td>5I</td><td>4I 2II</td></tr> <tr><td>5</td><td>3I 1II</td><td>5I 2II</td></tr> <tr><td>6</td><td>4I 1II</td><td>4I 3II</td></tr> </tbody> </table>	D6	A	B	1	2I	4I	2	3I	3I 1II	3	4I	4I 1II	4	5I	4I 2II	5	3I 1II	5I 2II	6	4I 1II	4I 3II
D6	A	B																						
1	2I	4I																						
2	3I	3I 1II																						
3	4I	4I 1II																						
4	5I	4I 2II																						
5	3I 1II	5I 2II																						
6	4I 1II	4I 3II																						
Notes _____ _____ _____																								

Mission Map #03

Turns

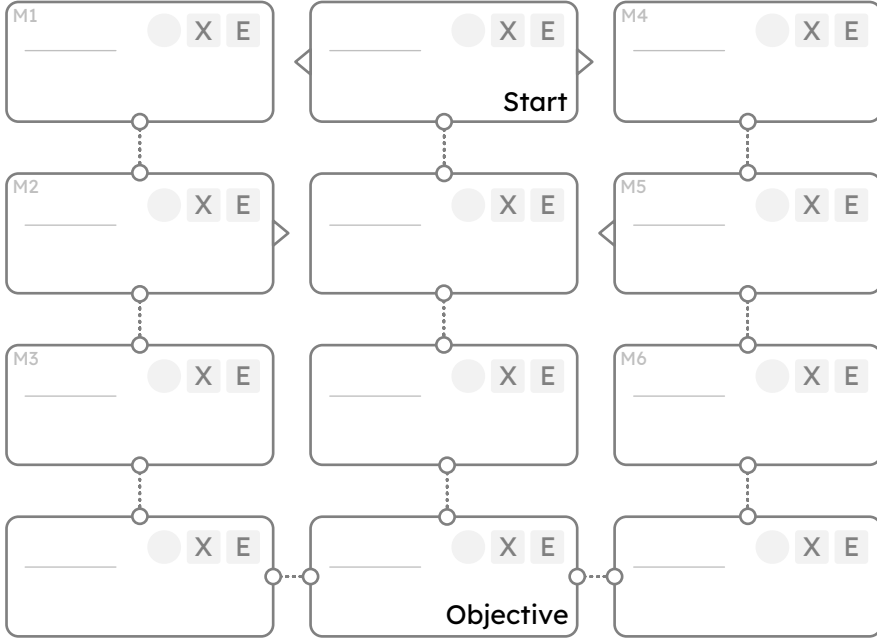

01	13
02	14
03	15
04	16
05	17
06	18
07	19
08	20
09	21
10	22
11	23
12	24

Squad

Leader CMD 4 CP ○ ○ ♥	F M _____ ADV 3 ♥ ♥	F M _____ ADV 3 ♥ ♥	F M _____ ADV 3 ♥ ♥	F M _____ ADV 3 ♥ ♥	Spec 1 ♥ Spec 2 ♥
---	------------------------------	------------------------------	------------------------------	------------------------------	--

Resources I _____ M _____ G _____ SG _____ D _____ S _____

Enemies

Type I F _____ M _____ ♥ ♥ ♥ ♥ ♥ ♥ ♥ ♥ ♥ ♥	Type II F _____ M _____ Special: _____ ♥ ♥ ♥ (A) (A) ♥ ♥ ♥ (A) (A) ♥ ♥ ♥ (A) (A) 	Ranges Melee Fire - - ↓ ↓ ○ 1 ○ ○ 2 ○ ○ 3 ○ ○ 4 ○ ○ 5 ○ ○ 6 ○ ○ 7 ○ ○ 8 ○	<table border="1"> <thead> <tr> <th>EPT</th> <th>D6</th> <th>A</th> <th>B</th> </tr> </thead> <tbody> <tr><td>1</td><td>2I</td><td>4I</td></tr> <tr><td>2</td><td>3I</td><td>2I 1II</td></tr> <tr><td>3</td><td>3I</td><td>3I 1II</td></tr> <tr><td>4</td><td>4I</td><td>5I 1II</td></tr> <tr><td>5</td><td>5I</td><td>4I 2II</td></tr> <tr><td>6</td><td>3I 1II</td><td>3I 3II</td></tr> </tbody> </table>	EPT	D6	A	B	1	2I	4I	2	3I	2I 1II	3	3I	3I 1II	4	4I	5I 1II	5	5I	4I 2II	6	3I 1II	3I 3II
EPT	D6	A	B																						
1	2I	4I																							
2	3I	2I 1II																							
3	3I	3I 1II																							
4	4I	5I 1II																							
5	5I	4I 2II																							
6	3I 1II	3I 3II																							
Notes																									

Mission Map #04

Turns

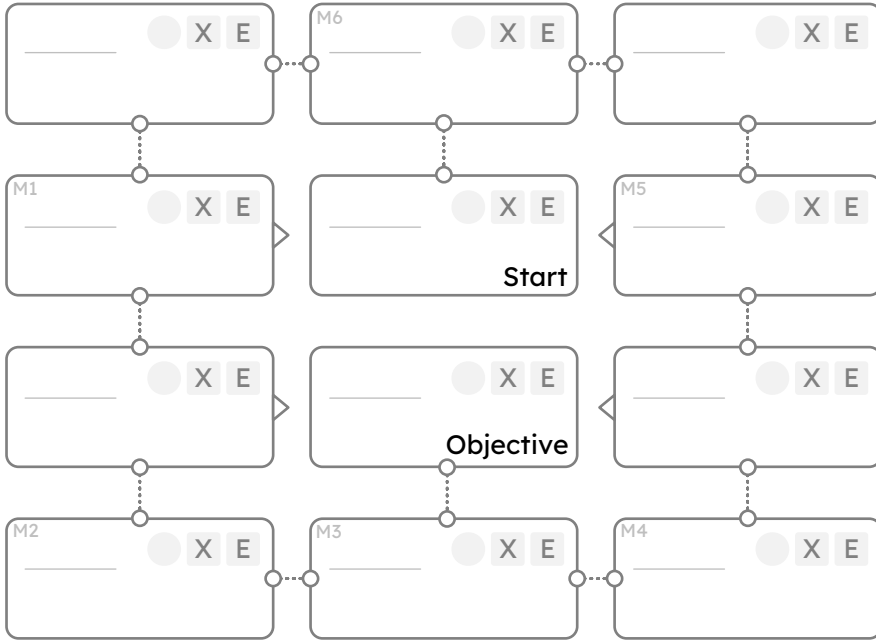

01	13
02	14
03	15
04	16
05	17
06	18
07	19
08	20
09	21
10	22
11	23
12	24

Squad

Leader CMD 4 CP ○ ○ ♥	F _____ M _____ ADV 3 ♥ ♥	F _____ M _____ ADV 3 ♥ ♥	F _____ M _____ ADV 3 ♥ ♥	F _____ M _____ ADV 3 ♥ ♥	Spec 1 _____ ♥ Spec 2 _____ ♥
---	------------------------------------	------------------------------------	------------------------------------	------------------------------------	--

Resources I _____ M _____ G _____ SG _____ D _____ S _____

Enemies

Type I F _____ M _____ ♥ ♥ ♥ ♥ ♥ ♥ ♥ ♥ ♥ ♥	Type II F _____ M _____ Special: _____ ♥ ♥ ♥ (A) (A) ♥ ♥ ♥ (A) (A) ♥ ♥ ♥ (A) (A) 	Ranges Melee _____ Fire _____ - - ○ 1 ○ ○ 2 ○ ○ 3 ○ ○ 4 ○ ○ 5 ○ ○ 6 ○ ○ 7 ○ ○ 8 ○	EPT <table border="1"> <thead> <tr> <th>D6</th> <th>A</th> <th>B</th> </tr> </thead> <tbody> <tr><td>1</td><td>1I</td><td>5I</td></tr> <tr><td>2</td><td>2I</td><td>1I 1II</td></tr> <tr><td>3</td><td>3I</td><td>2I 1II</td></tr> <tr><td>4</td><td>4I</td><td>4I 1II</td></tr> <tr><td>5</td><td>5I</td><td>4I 2II</td></tr> <tr><td>6</td><td>2I 1II</td><td>3I 3II</td></tr> </tbody> </table>	D6	A	B	1	1I	5I	2	2I	1I 1II	3	3I	2I 1II	4	4I	4I 1II	5	5I	4I 2II	6	2I 1II	3I 3II
D6	A	B																						
1	1I	5I																						
2	2I	1I 1II																						
3	3I	2I 1II																						
4	4I	4I 1II																						
5	5I	4I 2II																						
6	2I 1II	3I 3II																						
Notes _____ _____ _____																								

Mission Map # _____

Turns

_____ ● X E

_____ ● X E

_____ ● X E

_____ ● X E

_____ ● X E

_____ ● X E

_____ ● X E

_____ ● X E

_____ ● X E

_____ ● X E

_____ ● X E

_____ ● X E

01	13
02	14
03	15
04	16
05	17
06	18
07	19
08	20
09	21
10	22
11	23
12	24

Squad

Leader CMD 4 CP ○ ○ ♥	F _____ M _____ ADV 3 ♥ ♥	F _____ M _____ ADV 3 ♥ ♥	F _____ M _____ ADV 3 ♥ ♥	F _____ M _____ ADV 3 ♥ ♥	Spec 1 _____ ♥ Spec 2 _____ ♥
---	------------------------------------	------------------------------------	------------------------------------	------------------------------------	--

Resources I _____ M _____ G _____ SG _____ D _____ S _____

Enemies

Type I F _____ M _____ ♥ ♥ ♥ ♥ ♥ ♥ ♥ ♥ ♥ ♥	Type II F _____ M _____ Special: _____ ♥ ♥ ♥ (A) (A) ♥ ♥ ♥ (A) (A) ♥ ♥ ♥ (A) (A) ♥ ♥ ♥ (A) (A) ♥ ♥ ♥ (A) (A)	Ranges Melee _____ Fire _____ - - ↓ ↓ ○ 1 ○ ○ 2 ○ ○ 3 ○ ○ 4 ○ ○ 5 ○ ○ 6 ○ ○ 7 ○ ○ 8 ○	EPT <table border="1"> <thead> <tr><th>D6</th><th>A</th><th>B</th></tr> </thead> <tbody> <tr><td>1</td><td></td><td></td></tr> <tr><td>2</td><td></td><td></td></tr> <tr><td>3</td><td></td><td></td></tr> <tr><td>4</td><td></td><td></td></tr> <tr><td>5</td><td></td><td></td></tr> <tr><td>6</td><td></td><td></td></tr> </tbody> </table>	D6	A	B	1			2			3			4			5			6			Notes _____ _____ _____ _____ _____
D6	A	B																							
1																									
2																									
3																									
4																									
5																									
6																									

Mission Map: Base Defense

Turns

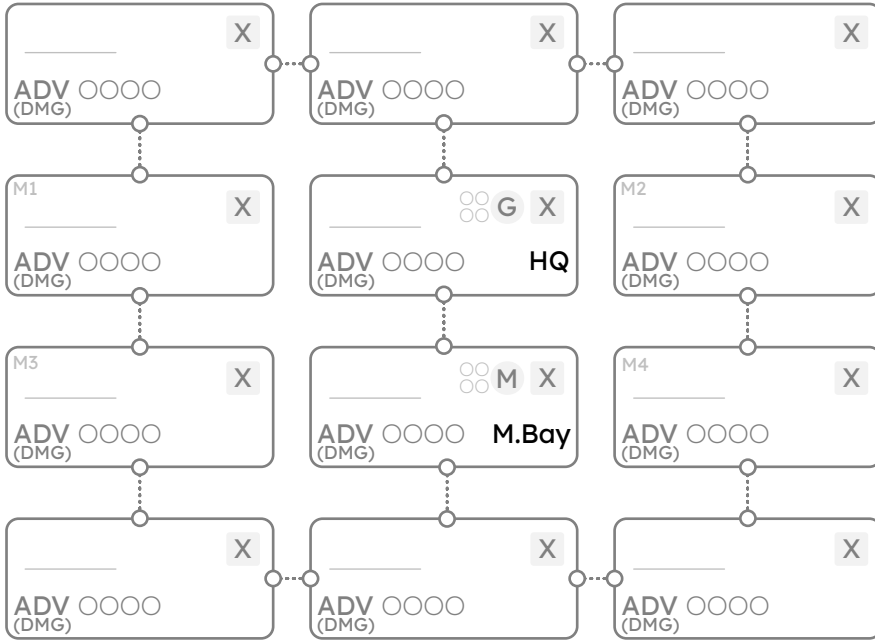

01-A	13-A
02-A	14-A
03-A	15-A
04-B	16-B
05-A	17-A
06-A	18-A
07-A	19-A
08-B	20-B
09-A	21-A
10-A	22-A
11-A	23-A
12-B	24-B

Squad

Leader					
	F	F	F	F	F
	M	M	M	M	M
CMD 4	ADV 3	ADV 3	ADV 3	ADV 3	ADV 3
CP ○ ○					
♡	♡ ♡	♡ ♡	♡ ♡	♡ ♡	♡ ♡

Resources I _____ M _____ G _____ SG _____ D _____ S _____

Enemies

Type I	Type II	Ranges	D6	EPT A	EPT B	<u>Sequence</u> Adv. Turn E. Arrival Gen. CP Spend CP Move Combat E. Actions Resupply
F _____	F _____	Melee Fire	1	2I	5I	
M _____	M _____	- -	2	3I	2I 1II	
	Special:	↓ ↓	3	4I	3I 1II	
♡ ♡	♡ ♡ ♡	○ 1 ○	4	5I	4I 1II	
♡ ♡	♡ ♡ ♡	○ 2 ○	5	3I 1II	3I 2II	
♡ ♡	♡ ♡ ♡	○ 3 ○	6	4I 1II	3I 3II	
♡ ♡	♡ ♡ ♡	○ 4 ○	D6 Enemy Action			
♡ ♡	♡ ♡ ♡	○ 5 ○	1-3	Move toward HQ or M.Bay		
♡ ♡	♡ ♡ ♡	○ 6 ○	4-5	One location damage		
♡ ♡	♡ ♡ ♡	○ 7 ○	6	Two location damage		
♡ ♡	♡ ♡ ♡	○ 8 ○				